

DEHN & SÖHNE Spark Gap Arrester 923062 EXFS-L

Savcor Product code: 835-94020 (300mm long Cable)

Lightning impulse current (10/350) _{I_{imp}}	50kA
Classification of lightning current carrying capability acc. To EN 50164-3	N
Nominal discharge current (8/20) _{I_n}	100kA
Rated power frequency	300v
100% lightning impulse sparkeover voltage U _{as 100}	≤2.5kV
Power frequency sparkover voltage (50 Hz) U _{aw}	≤1.2kV
Type of protection according to EN 50014, EN 50021	⊕ II 3 G EEx nC II T4
Operating Temperature	-20 ⁰ c to +80 ⁰ c
Degree of Protection	IP54
Approvals, Certifications	ZELM 03 ATEX 3192X (IEC Ex certification pending)
Enclosure Length (L)	90mm
Diameter of enclosure (D)	63mm
Enclosure material	Zinc diecasting, plastic
Connecting cable	100, 200 & 300mm long
Suitable for flange size	20-320mm

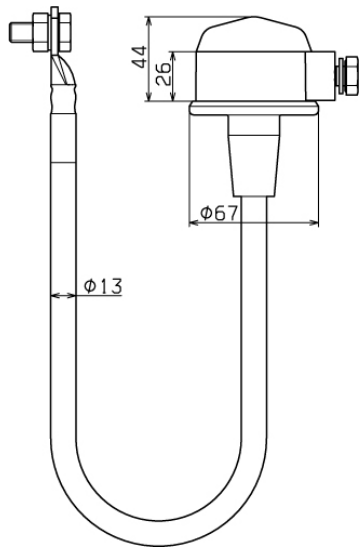

Dimension Drawing EXFS

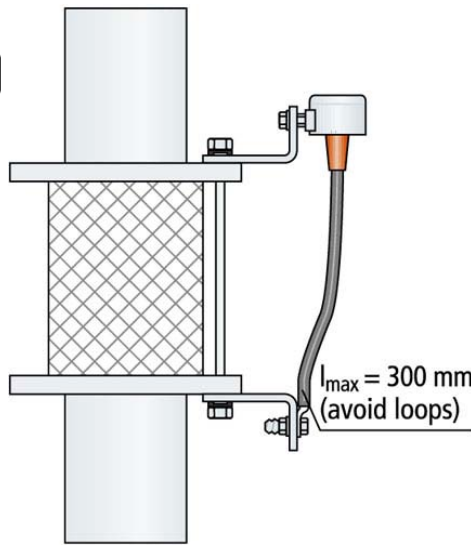

Installation of EXFS



EXFS-L300

Vic/Tas/SA 03 9993 7500	NSW 02 9663 2322	NZ 09 414 5080	QLD/NT 07 3890 8533	WA 08 9248 8999
----------------------------	---------------------	-------------------	------------------------	--------------------

All written data and statements herein are provided in good faith and believed to be reliable and appropriate at the time of drafting this document. However it is given without implied or express guarantee. Potential uses are urged to trial and /or conduct conformity test of the product to deem its suitable in application for a particular end use prior to purchase.